

AMR58 AMR58S AMRC



with integrated cam programmer



- Multiturn encoder with integrated cam programmer
- Multiturn resolution 4096 cpr x 256 revolutions
- 8 outputs, up to 120 programmable cams per each output
- Max. 16 storable programs
- Additional SSI output

Suitable for the following models:

- AMR58
- AMR58S
- AMRC

General Contents

Preliminary information	7
1 - Safety summary	8
2 - Identification	10
3 - Mechanical installation	11
4 - Electrical connection	16
5 - Set up	20
6 - Programming software	24

This publication was produced by Lika Electronic s.r.l. 2017. All rights reserved. Tutti i diritti riservati. Alle Rechte vorbehalten. Todos los derechos reservados. Tous droits réservés.

This document and information contained herein are the property of Lika Electronic s.r.l. and shall not be reproduced in whole or in part without prior written approval of Lika Electronic s.r.l. Translation, reproduction and total or partial modification (photostat copies, film and microfilm included and any other means) are forbidden without written authorisation of Lika Electronic s.r.l.

The information herein is subject to change without notice and should not be construed as a commitment by Lika Electronic s.r.l. Lika Electronic s.r.l. reserves the right to make all modifications at any moments and without forewarning.

This manual is periodically reviewed and revised. As required we suggest checking if a new or updated edition of this document is available at Lika Electronic s.r.l.'s website. Lika Electronic s.r.l. assumes no responsibility for any errors or omissions in this document. Critical evaluation of this manual by the user is welcomed. Your comments assist us in preparation of future documentation, in order to make it as clear and complete as possible. Please send an e-mail to the following address info@lika.it for submitting your comments, suggestions and criticisms.

The logo for Lika Electronic s.r.l. consists of the word "lika" in a bold, lowercase, sans-serif font. The letter "i" has a dot, and the "a" has a tail that extends to the right.

General Contents

User's guide.....	1
General Contents.....	3
Subject Index.....	5
Typographic and iconographic conventions.....	6
Preliminary information.....	7
1 - Safety summary.....	8
1.1 Safety.....	8
1.2 Electrical safety.....	8
1.3 Mechanical safety.....	9
2 - Identification.....	10
3 - Mechanical installation.....	11
3.1 Encoder with solid shaft (models AMR58, AMR58S).....	11
3.1.1 Customary installation.....	11
3.1.2 Installation using fixing clamps (optional kit code LKM 386).....	12
3.1.3 Installation using a mounting bell (code PF4256).....	12
3.2 Encoder with hollow shaft (model AMRC).....	13
3.2.1 Installation using the antirotation pin (customary installation).....	13
3.2.2 Installation using the fixing plate (optional kit code xx59).....	14
3.2.3 Installation using the antirotation pin and fixing plate (optional kit code xx60).....	15
4 - Electrical connection.....	16
4.1 Connection options.....	16
4.2 A32 cable specifications.....	17
4.3 MIL 32-pin connector specifications.....	17
4.4 Connection of the shield.....	17
4.5 Ground connection.....	18
4.6 RS-232 serial interface.....	18
5 - Set up.....	20
5.1 Description of functions.....	20
Data OUT +.....	20
Data OUT -.....	20
Clock IN +.....	20
Clock IN -.....	20
Load Program.....	20
Select Program 2x.....	21
Fault.....	21
RxD RS-232.....	21
TxD RS-232.....	21
OVdc RS-232.....	21
Preset.....	21
Counting direction.....	22
5.2 Accessories.....	22
5.3 Reading the encoder position via RS-232.....	23
CHK.....	23
6 - Programming software.....	24
6.1 Connection between personal computer and encoder.....	24
6.2 Software installation.....	24

6.3 Main window.....	26
6.3.1 Tools menu.....	27
Programming	27
6.3.2 Settings menu.....	27
Model	27
Language	27
COM port settings	27
Filter	27
Enable ECON	28
6.4 Programming window.....	28
Verify	29
Select all	29
Deselect all	29
Synchronize	29
Append	29
Send Program to Encoder (Download)	29
Multiple Files	29
6.4.1 File menu.....	30
Load Progr.	30
Save Progr.	30
Load List	30
Save List	30
Import (from ENCODER)	30
6.4.2 Settings menu.....	30
6.5 Work files (Working programs).....	31
6.5.1 Work files (Working programs) diagnostic.....	32
6.5.2 File extension.....	32
6.5.3 Errors.....	33

Subject Index



A		Model.....	27
Advanced.....	27	Multiple Files.....	29
Append.....	29	O	
C		Off line.....	26
CLONE.....	30	Offsets.....	28
COM port settings.....	27	Origin value.....	30
D		P	
Deselect all.....	29	PRESET.....	30
E		Programming.....	27
Enable ECON.....	28	R	
F		READ.....	30
Filter.....	27	S	
I		Save List.....	30
Import (from ENCODER).....	30	Save Progr.....	30
L		Select all.....	29
Language.....	27	SEND.....	31
Load List.....	30	Send Program to Encoder (Download).....	29
Load Progr.....	30	Synchronize.....	29
M		V	
		Verify.....	29

Typographic and iconographic conventions

In this guide, to make it easier to understand and read the text the following typographic and iconographic conventions are used:

- parameters and objects both of the device and the interface are coloured in **GREEN**;
- alarms are coloured in **RED**;
- states are coloured in **FUCSIA**.

When scrolling through the text some icons can be found on the side of the page: they are expressly designed to highlight the parts of the text which are of great interest and significance for the user. Sometimes they are used to warn against dangers or potential sources of danger arising from the use of the device. You are advised to follow strictly the instructions given in this guide in order to guarantee the safety of the user and ensure the performance of the device. In this guide the following symbols are used:

	This icon, followed by the word WARNING , is meant to highlight the parts of the text where information of great significance for the user can be found: user must pay the greatest attention to them! Instructions must be followed strictly in order to guarantee the safety of the user and a correct use of the device. Failure to heed a warning or comply with instructions could lead to personal injury and/or damage to the unit or other equipment.
	This icon, followed by the word NOTE , is meant to highlight the parts of the text where important notes needful for a correct and reliable use of the device can be found. User must pay attention to them! Failure to comply with instructions could cause the equipment to be set wrongly: hence a faulty and improper working of the device could be the consequence.
	This icon is meant to highlight the parts of the text where suggestions useful for making it easier to set the device and optimize performance and reliability can be found. Sometimes this symbol is followed by the word EXAMPLE when instructions for setting parameters are accompanied by examples to clarify the explanation.

Preliminary information

This guide is designed to provide the most complete information the operator needs to correctly and safely install and operate the following encoders **with integrated cam programmer**:

- **AMR58;**
- **AMR58S;**
- **AMRC.**

AMR58 is the multiturn optical encoder equipped with eight programmable cam outputs. Each output allows to switch a peripheral device by using the position signal of the integral encoder. In this way the output signals are more precise and even actually "real time". For each output you can programme at desired points up to 120 so-called electronic cams, i.e. changes of state in each peripheral device. Then you can save the set configuration to the internal memory which allows you to store max. 16 programs. Four inputs enable to select the desired program on board, thus making also frequent changeovers more simple and quick.

For technical specifications please refer to the product datasheet.

1 - Safety summary

1.1 Safety

- Always adhere to the professional safety and accident prevention regulations applicable to your country during device installation and operation;
- installation and maintenance operations have to be carried out by qualified personnel only, with power supply disconnected and stationary mechanical parts;
- device must be used only for the purpose appropriate to its design: use for purposes other than those for which it has been designed could result in serious personal and/or the environment damage;
- high current, voltage and moving mechanical parts can cause serious or fatal injury;
- warning ! Do not use in explosive or flammable areas;
- failure to comply with these precautions or with specific warnings elsewhere in this manual violates safety standards of design, manufacture, and intended use of the equipment;
- Lika Electronic assumes no liability for the customer's failure to comply with these requirements.

1.2 Electrical safety

- Turn off power supply before connecting the device;
- connect according to explanation in the "4 - Electrical connection" section on page 16;
- wires which are not used must be cut at different lengths and insulated singularly;
- connect Preset and Counting direction inputs to 0Vdc, if not used;
 - to set the preset, connect Preset to +Vdc for 100 μ s at least, then disconnect +Vdc; normally voltage must be at 0Vdc; preset setting must be performed after Counting direction; we suggest setting the preset when the encoder is in stop;
 - Counting direction: CW increasing count (viewed from shaft side) = connect to 0Vdc; CCW increasing count = connect to +Vdc;
- Load program input: to load the selected program connect the input to 0Vdc for 10 ms at least. The program will be loaded automatically at start-up. Never connect to +Vdc; 
- Program 2^x inputs: set the binary value of the program to load minus 1, i.e. program 5 = 0100_2 / pin 21, 20, 19, 18 = 4_{10} ($4 + 1 = 5$);
- in compliance with the 2014/30/EU norm on electromagnetic compatibility, following precautions must be taken:
 - before handling and installing, discharge electrical charge from your body and tools which may come in touch with the device;
 - power supply must be stabilized without noise, install EMC filters on device power supply if needed;

- always use shielded cables (twisted pair cables whenever possible);
- avoid cables runs longer than necessary;
- avoid running the signal cable near high voltage power cables;
- mount the device as far as possible from any capacitive or inductive noise source, shield the device from noise source if needed;
- to guarantee a correct working of the device, avoid using strong magnets on or near by the unit;
- minimize noise by connecting the shield and/or the connector housing and/or the frame to ground. Make sure that ground is not affected by noise. The connection point to ground can be situated both on the device side and on user's side. The best solution to minimize the interference must be carried out by the user.

1.3 Mechanical safety

- Install the device following strictly the information in the "3 – Mechanical installation" section on page 11;
- mechanical installation must be carried out with stationary mechanical parts;
- do not disassemble the encoder;
- do not tool the encoder or its shaft;
- delicate electronic equipment: handle with care; do not subject the device and the shaft to knocks or shocks;
- respect the environmental characteristics declared by manufacturer;
- unit with solid shaft: in order to guarantee the maximum reliability over time of the mechanical parts, we recommend a flexible coupling to be installed to connect the encoder and the installation shaft; make sure the misalignment tolerances of the flexible coupling are respected;
- unit with hollow shaft: the encoder can be mounted directly on a shaft whose diameter has to respect the technical characteristics specified in the purchase order and clamped by means of the collar and the fixing plate into which an anti-rotation pin has to be inserted.

2 - Identification

Device can be identified through the **order code** and the **serial number** printed on the label applied to its body. Information is listed in the delivery document too. Please always quote the order code and the serial number when reaching Lika Electronic for purchasing spare parts or needing assistance. For any information on the technical characteristics of the product refer to the technical catalogue.



Warning: encoders having order code ending with "/Sxxx" may have mechanical and electrical characteristics different from standard and be supplied with additional documentation for special connections (Technical Info).

3 – Mechanical installation



WARNING

Installation must be carried out by qualified personnel only, with power supply disconnected and mechanical parts compulsorily in stop.

3.1 Encoder with solid shaft (models AMR58, AMR58S)

3.1.1 Customary installation

- Mount the flexible coupling **1** on the encoder shaft;
- fix the encoder to the flange **2** (or to the mounting bell) by means of screws **3**;
- secure the flange **2** to the support (or the mounting bell to the motor);
- mount the flexible coupling **1** on the motor shaft;
- make sure the misalignment tolerances of the flexible coupling **1** are respected.

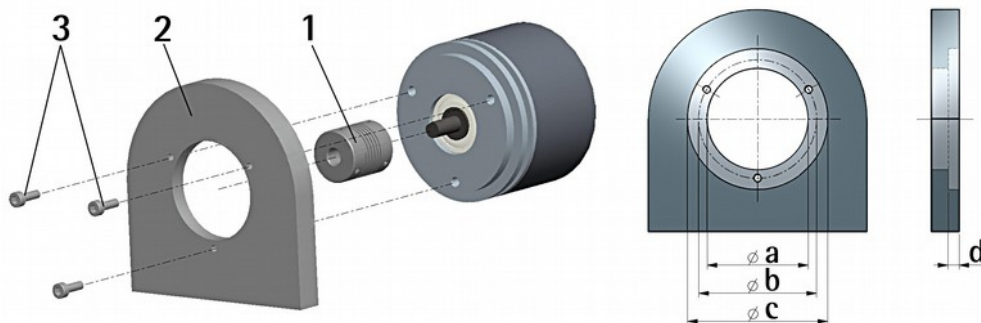

	a [mm]	b [mm]	c [mm]	d [mm]
AMR58 – standard flange	-	42	50 F7	4
AMR58S – flange with pilot	36 H7	48	-	-

3.1.2 Installation using fixing clamps (optional kit code LKM 386)

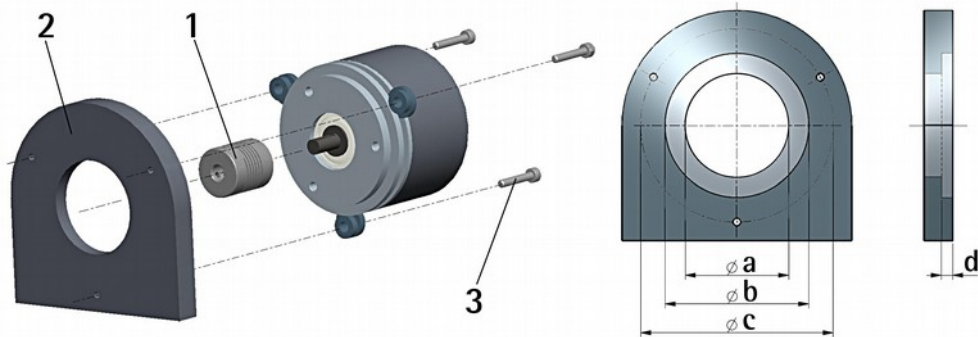

	a [mm]	b [mm]	c [mm]	d [mm]
AMR58 – standard flange	-	50 F7	67	4
AMR58S – flange with pilot	36 H7	-	67	-

3.1.3 Installation using a mounting bell (code PF4256)

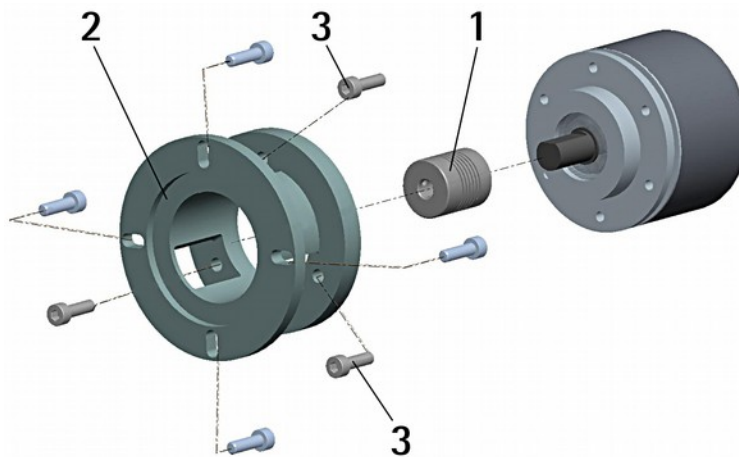

NOTE

In order to guarantee reliability over time of the encoder mechanical parts, we recommend a flexible coupling to be installed between the encoder and the motor shaft.

3.2 Encoder with hollow shaft (model AMRC)

3.2.1 Installation using the antirotation pin (customary installation)

- Fasten the anti-rotation pin **1** to the rear of the motor (secure it using a locknut);
- mount the encoder on the motor shaft using the reducing sleeve **8** (if supplied). Avoid forcing the encoder shaft;
- insert the anti-rotation pin **1** into the slot on the flange of the encoder; this secures it in place by grub screw **2**, preset at Lika;
- fix the collar **3** to the encoder shaft.

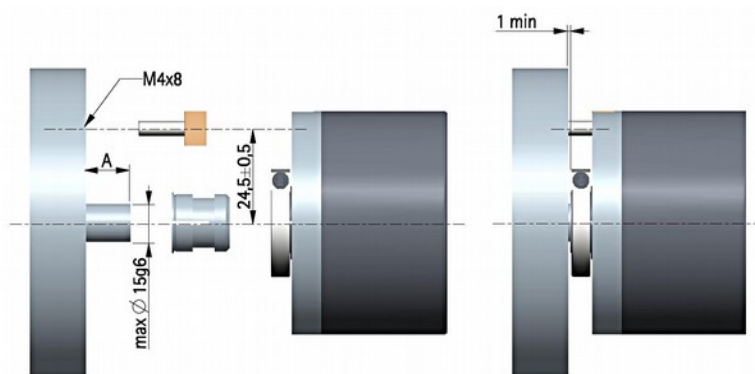
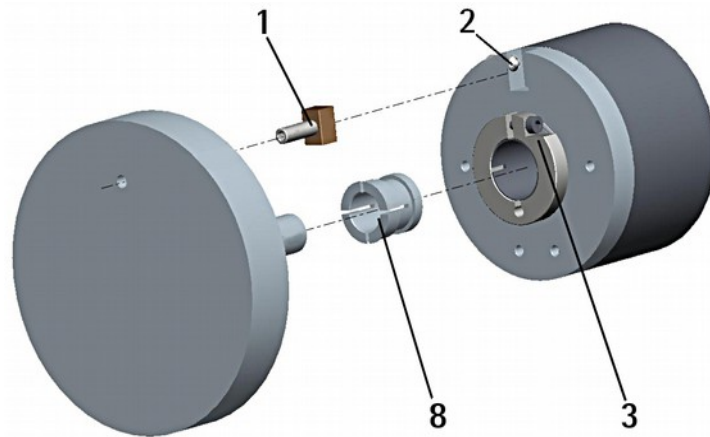

3.2.2 Installation using the fixing plate (optional kit code xx59)

- Remove the antirotation pin 1 (see Figure in the previous page);
- mount the encoder on the motor shaft using the reducing sleeve 8 (if supplied). Avoid forcing the encoder shaft;
- fasten the fixing plate 4 to the rear of the motor using two M3 x 8 cylindrical head screws 5;
- fix the collar 3 to the encoder shaft.

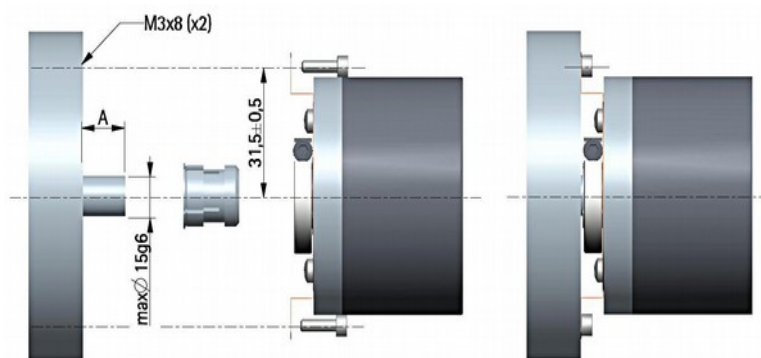
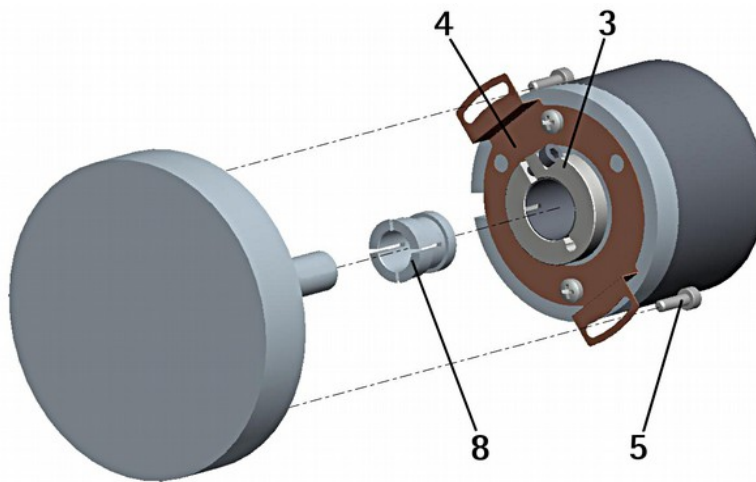

3.2.3 Installation using the antirotation pin and fixing plate (optional kit code xx60)

- Remove the antirotation pin **1** (see Figure on page 13);
- fix the tempered pin **6** to the rear of the motor;
- mount the encoder on the motor shaft using the reducing sleeve **8** (if supplied). Avoid forcing the encoder shaft;
- make sure the anti-rotation pin **6** is inserted properly into the fixing plate **7**;
- fix the collar **3** to the encoder shaft.

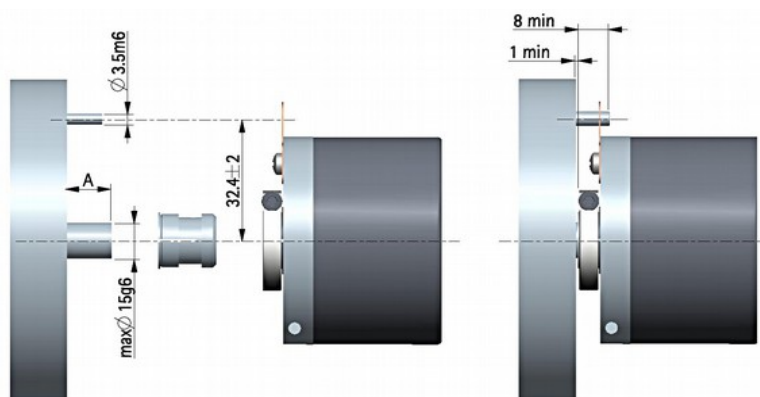
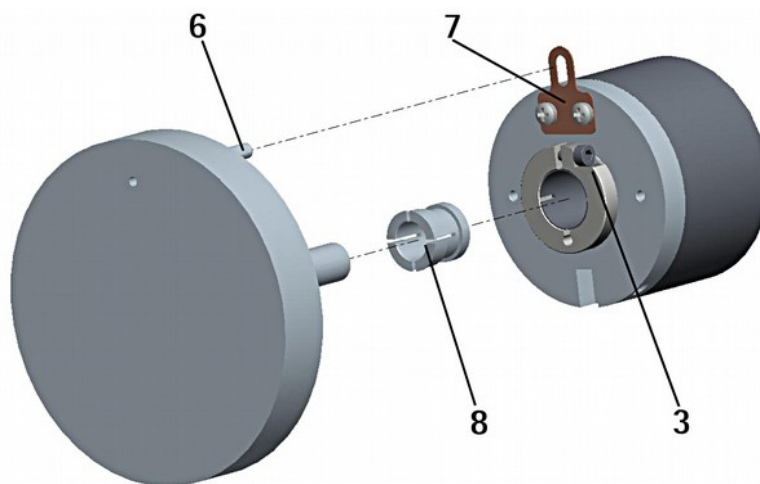

NOTE

You are strongly advised not to carry out any mechanical operations (drilling, milling, etc.) on the encoder shaft. This could cause serious damages to the internal parts and an immediate warranty loss. Please contact our technical personnel for the complete availability of "custom made" shafts.

4 - Electrical connection



WARNING

Electrical connection must be carried out by qualified personnel only, with power supply disconnected and mechanical parts compulsorily in stop.



WARNING

If wires of unused signals come in contact, irreparable damage could be caused to the device. Please insulate them singularly.

4.1 Connection options

Two connection options are available: through either A32 cable or MIL 32-pin connector. For a complete description of the available functions please refer to the "5 - Set up" section on page 20.

Function	A32 cable	MIL 32-pin connector
OUT 1	Brown	A
OUT 2	Red	B
OUT 3	Pink	C
OUT 4	Yellow	D
OUT 5	Green	E
OUT 6	Blue	F
OUT 7	Violet	G
OUT 8	Grey	H
Data OUT +	Blue/Red	N
Data OUT -	Pink/Grey	P
Clock IN +	White/Yellow	R
Clock IN -	Brown/Green	S
Load Program (1)	White/Green	T
Select Program 2 ⁰ (2)	Yellow/Brown	U
Select Program 2 ¹ (2)	White/Blue	V
Select Program 2 ² (2)	Brown/Blue	W
Select Program 2 ³ (2)	White/Pink	X
Fault	White/Grey	Y
RxD RS-232 (3)	Pink/Brown	Z
TxD RS-232 (3)	Grey/Brown	a
0Vdc (4)	Brown/Black	b
0Vdc RS-232 (5)	White/Black	c
Preset	Grey/Green	d
Counting direction	Yellow/Pink	g
+10Vdc +30Vdc Power supply	Green/Blue + Pink/Green	h
0Vdc Power supply (4)	Yellow/Blue + Yellow/Grey	j
Shield	Shield	Case



NOTE

1. Connect the input to 0Vdc for 10 ms at least to load the program. The program will be loaded automatically at start-up. Warning: do not connect to +Vdc.
2. Select program 2^x inputs are internally connected to 0Vdc through push-pull resistors. They are active at +Vdc.
3. Please always make sure that the RxD of the ENCODER is cross-wired to the TxD of the PC while the TxD is cross-wired to the RxD.
4. 0Vdc and 0Vdc Power supply are internally connected.
5. 0Vdc RS-232 is internally insulated from 0Vdc Power supply.

4.2 A32 cable specifications

Model	: LIKA A32 Li-YCY cable
Wires	: 32 x 0.14 mm ²
Shield	: tinned copper braid
External diameter	: Ø 9.1 mm ± 5%
Impedance	: ≤ 148 Ω/Km at 20°C
Minimum bending radius	: fixed = 5 x Ø; flexible = 10 x Ø

4.3 MIL 32-pin connector specifications

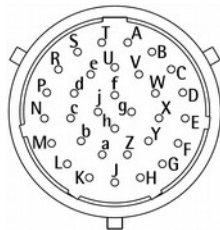

MIL 32-pin connector
Male
Clockwise

4.4 Connection of the shield

For signals transmission always use shielded cables. The cable shielding must be connected properly to the metal ring nut **3** of the connector in order to ensure a good earthing through the frame of the device. To do this disentangle and shorten the shielding **1** and then bend it over the part **2**; finally place the ring nut **3** of the connector. Be sure that the shielding **1** is in tight contact with the ring nut **3**.

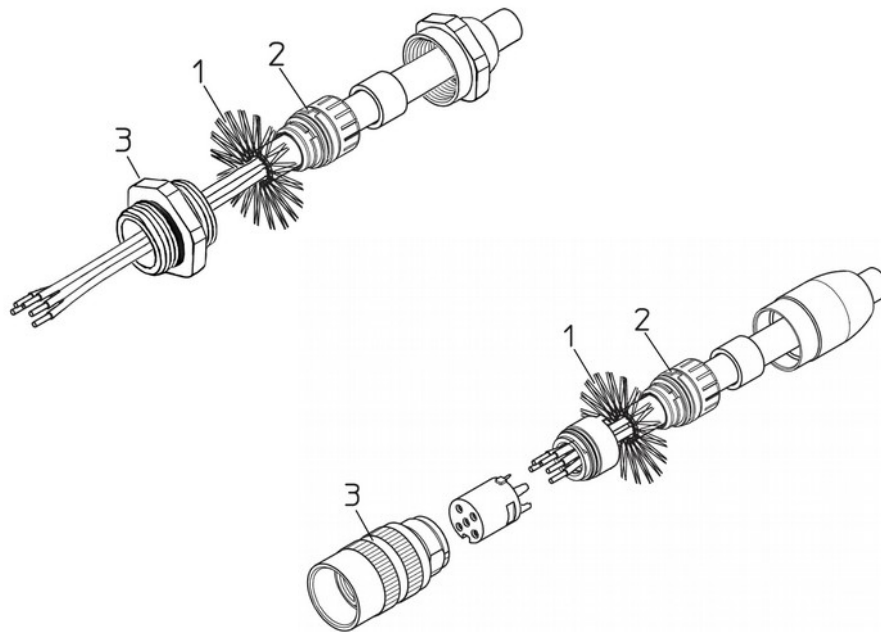

4.5 Ground connection

Minimize noise by connecting the shield and/or the connector housing and/or the frame to ground. Make sure that ground is not affected by noise. The connection point to ground can be situated both on the device side and on user's side. The best solution to minimize the interference must be carried out by the user. You are advised to provide the ground connection as close as possible to the encoder.

4.6 RS-232 serial interface

This encoder is equipped with a serial interface; it allows you to program the device. A software tool designed to program the encoder via RS-232 interface is available at the address www.lika.biz > **ROTARY ENCODERS** > **ABSOLUTE ENCODERS** > **SSI** > **AMR58**. Before starting the program, connect the device to the personal computer through a serial port. Should the personal computer not be equipped with a serial port, you must install a USB / RS-232 converter, easily available in the market.

The serial cable must be connected as shown in the following page.

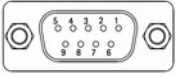
ENCODER SIDE			PC SIDE	
Function	A32 cable	 MIL 32-pin	 DSub 9-pin female	Function
TxD	Grey/Brown	a	2	RxD
RxD	Pink/Brown	Z	3	TxD
0Vdc RS-232	White/Black	c	5	0Vdc
0Vdc	Yellow/Blue + Yellow/Grey	j		
+Vdc	Green/Blue + Pink/Green	h		



NOTE

Please always make sure that the RxD of the ENCODER is cross-wired to the TxD of the PC while the TxD is cross-wired to the RxD.

IF92 kit with USB / RS-232 converter + optional **EC-AMR-M32F** cable are available for connection between the encoder and the PC.

Please note that the configuration parameters of the serial port have fixed values so the user cannot change them. They are:

RS-232 serial port settings	Default value
Baud rate	115200
Byte size	8
Parity	None
Stop bits	1
Flow control	None

5 – Set up

5.1 Description of functions

Data OUT +

Data OUT -

Clock IN +

Clock IN -

Data and clock lines of the auxiliary SSI interface for position information.

20-bit data is output in Binary code in compliance with the MSB LEFT ALIGNED protocol. The clock frequency can range between 100 kHz and 1 MHz while the pause time T_M (Time monoflop) is 12 μs . The output position information is the one of the active program, with consideration of the Preset value if set, as displayed in the main windows of the program interface (see on page 26).

MSB left aligned protocol allows to left align the data bits, beginning from MSB to LSB; MSB is then sent at the first clock cycle. If the number of clock signals is higher than the data bits, then unused bits are forced to logic level low (0) and follow the data word. Information can be variously arranged for single and multi-turn versions. The number of clocks to be sent to the encoder must equal at least the number of data bits, anyway it can be higher, as needed. The great advantage of this protocol over the TREE format and the LSB RIGHT ALIGNED format is that data can be transmitted with a minimum time loss and the T_m monoflop time can immediately follow the data bits without any additional clock signal. For any further information on the SSI interface refer to the document "SSI interface specifications" downloadable from Lika's web site. Here following are some examples of MSB LEFT ALIGNED protocol.

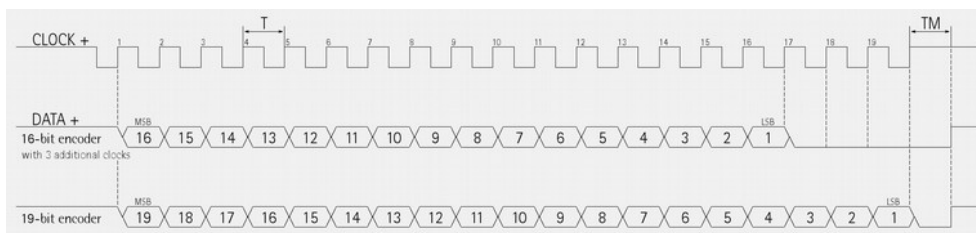

Load Program

It allows the operator to upload the selected program, see **Select Program 2x**. Connect the **Load Program** signal to 0Vdc for 10 ms at least. The program is selected through the **Select Program 2x** inputs and then loaded automatically at start up.



WARNING

Do not connect to +Vdc!

Select Program 2^x

You can select up to 16 programs using a binary code through the four dedicated inputs. Set the binary value of the X program to upload minus 1 (binary value = X - 1).

**EXAMPLE**

See the example below: code for selection of program n° 5:

Value	Sel. Prg. 2 ³	Sel. Prg. 2 ²	Sel. Prg. 2 ¹	Sel. Prg. 2 ⁰	
Binary	0	1	0	0	= 4 ₁₀

$$0100_2 = 4_{10}$$

$$\text{Program n° 5} = \text{Binary code} + 1.$$

Fault

Status of the outputs. The Fault signal indicates the status of the sixteen outputs. HIGH logic level indicates that:

- the encoder is receiving the program;
- the selected program is loading into EPROM;
- the selected program does not exist.

RxD RS-232**TxD RS-232****OVdc RS-232**

Opto-insulated RS-232 serial port for the programming and displaying via personal computer. For any information refer to the "4.6 RS-232 serial interface" section on page 18.

Preset

The output information can be forced through a command sent to the Preset input by a PLC or via a button.

To set the preset stop the encoder in the desired position and then connect Preset input to +Vdc for 100 μs at least.

After this, the position output by the encoder in that point will be the one set (and then loaded to the encoder) in the **Origin value** page in the **Settings** menu of the **Programming** window (see on page 30). By default the preset value is 0. Connect Preset input to 0Vdc if not used. To set the preset, connect Preset input to +Vdc for 100 μs at least, then disconnect +Vdc. Normally voltage

must be at 0Vdc. We suggest performing the preset setting when the encoder is in stop.

**WARNING**

The zero setting command modifies the position value (quote) of the program in use only (it does not change the quote of the other 15 programs).

Counting direction

The counting direction circuit is designed to reverse the counting direction. In other words it allows the count up information also when the shaft is rotating counter-clockwise. Connect the Counting direction input to 0Vdc if not used. Connect the Counting direction input to 0Vdc to have an increasing count (count up information) when the encoder is turning clockwise (CW, viewed from the shaft side); connect the Counting direction input to +Vdc to have an increasing count (count up information) when the encoder is turning counter-clockwise (CCW).

5.2 Accessories

- Programming software.
- External AC/DC power supply designed to supply the encoder during the programming via personal computer.
- Hand held simulation terminal designed to check the operation of the programs stored in the encoder without removing the encoder from the machine; no personal computer needed.

5.3 Reading the encoder position via RS-232

If you want to know the current position of the encoder send the following message:

Byte	Value
0	128
1 ... 17	0
18	CHK

The encoder will send you back a 19-byte message as follows:

Byte	Value
0	128
1	0
2	n° of active program
3	0
4 and 5	n° of programmed cams
6 ... 9	LSB ... MSB of current position
10 ... 13	0
14 ... 17	LSB ... MSB output pattern
18	CHK

CHK

Checksum. Byte used for the control of the correct message transmission. The CHK value is the unsigned sum of bytes from 0 to 17.

6 - Programming software

6.1 Connection between personal computer and encoder

Connect the personal computer and the encoder according to explanation in the "4 - Electrical connection" section on page 16.

6.2 Software installation

Before installing the utility software, close all the applications and uninstall any previous software versions.

To install the software proceed as follows. Please note that installer instructions are in Italian only. Please refer to the following notes for the comprehensive translation of the messages.

1. Double click the **SETUP.EXE** installer file: the following window will appear:



2. Press the **OK** button to continue. The next window will appear.

Rotacam Utilities installation program

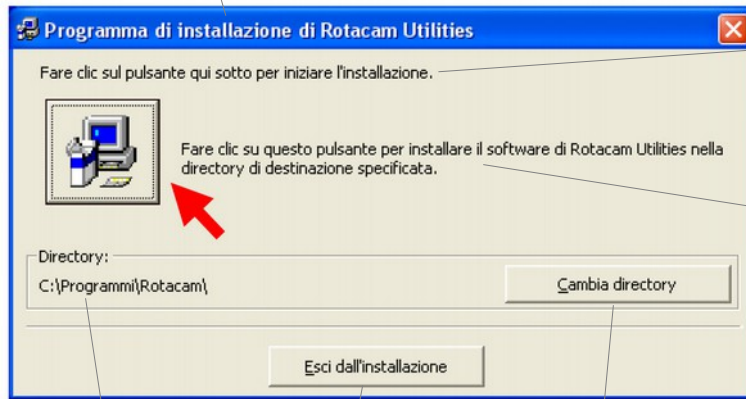

Press the button to start the installation

Click the button to install the Rotacam Utilities software in the default path

Default path

Abort installation

Change the directory path

3. Press the button indicated by the red arrow to continue installation. The next window will appear.

Rotacam Utilities – Choose the program group

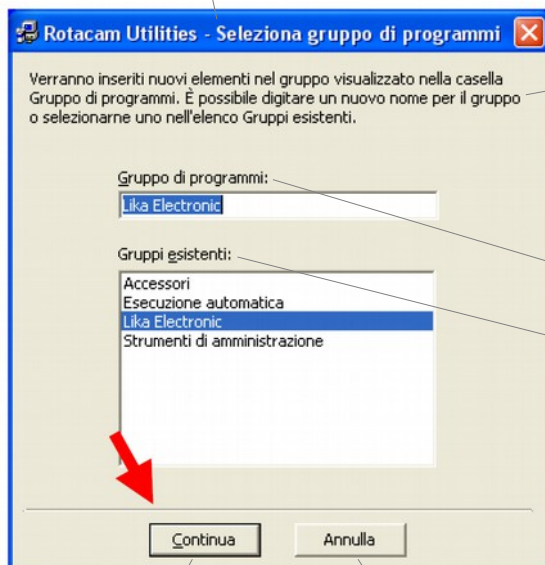

Setup will add new items to the group shown in the Program Group box. You can enter a new group name or select one from the Existing Groups list

Program Group box

Existing Groups box

Continue installation

Abort installation

4. Press the **Continua** button to finalize installation.

If you want, copy and paste the example files (demo.rcm) from the CAMME directory in the installation zip file to the work directory (C:\Lika\Rotacam).

6.3 Main window

To start the programming software and enter the main window of the tool double click the **Rotacam.exe** executable file.

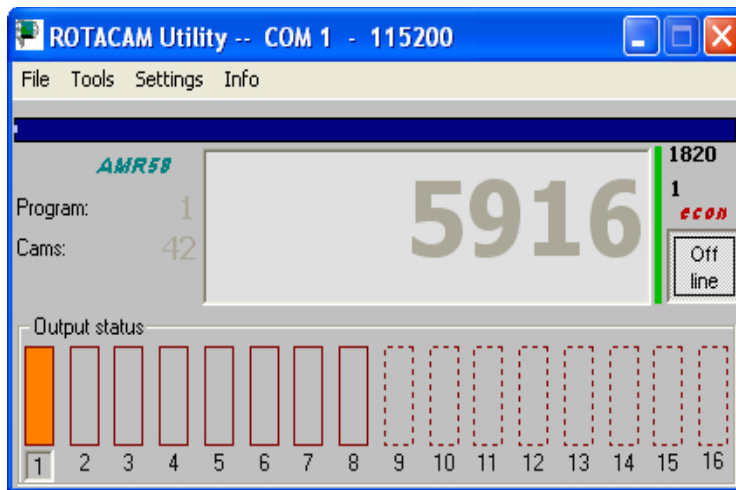

The **Off line** button is meant to close the serial communication and make the serial port available for other applications.

The current position of the encoder ("5916" value in the Figure above) and the graphical display of the active outputs (output status; "1", highlighted in orange below left in the Figure) as well as the number of the program in use (1) and the set cams (42) are shown in the main window. Furthermore the current position of the encoder in the revolution (1820) and the number of revolutions already performed (1) are shown at the top right of the window.

Between the **Off line** button and the position edit a vertical bar is available. It is meant to show the quality of the communication: when it is green it means that the communication between the personal computer and the encoder is proper; when the bar shortens or changes its colour (into yellow or red) it means that there is a problem in the serial communication (cable too long, noise, etc.).

If the position of the encoder is displayed intermittently, change the **Filter** value (see the "**Filter**" section below on page 27).

If there is no communication, the vertical bar is red and the position edit displays some dashes.

The serial port that is in use and its baud rate (COM 1 – 115200) are highlighted on the title bar.

If you minimize the main window to icon, the position of the encoder keeps being shown in the task bar.

6.3.1 Tools menu

Programming

It opens the window meant to manage, modify and download the encoder programs. For more information see the "6.4 Programming window" section on page 28.

6.3.2 Settings menu

Model

It allows the operator to choose the Rotacam encoder model connected to the personal computer.

Along with the AMR58/AMRC model described in this manual, also the ASR58/ASRC singleturn model, the previous ASR6 model and other special devices can be found in the list.

The utility software changes some of its characteristics according to the selected model.

Language

It allows the operator to choose the language used to display the menu bar, the buttons and the diagnostic messages.

COM port settings

It allows the operator to select the serial COM port of the personal computer connected to the encoder. Press the **Advanced** button to change the advanced settings of the COM port.

Filter

It allows the operator to increase the time-out interval when long cables or special encoders are used. It has to be set in case of communication problems (position value blinks, vertical bar is red, etc.). When the filter is set to "x10" or "x100" all the functions slow down. In this case, also the updating of the position value becomes slow.

For AMR58/AMRC, ASR58/ASRC and ASR6 encoders the default value is "x1", for S568 it is "x100".

Enable ECON

It enables the power and personal computer resources save mode. When the option is enabled, if the position value does not change in 2 minutes, the system goes into ECON mode and the serial port is tested every 2 seconds. As soon as the position value changes, the system exits immediately the power save mode.

6.4 Programming window

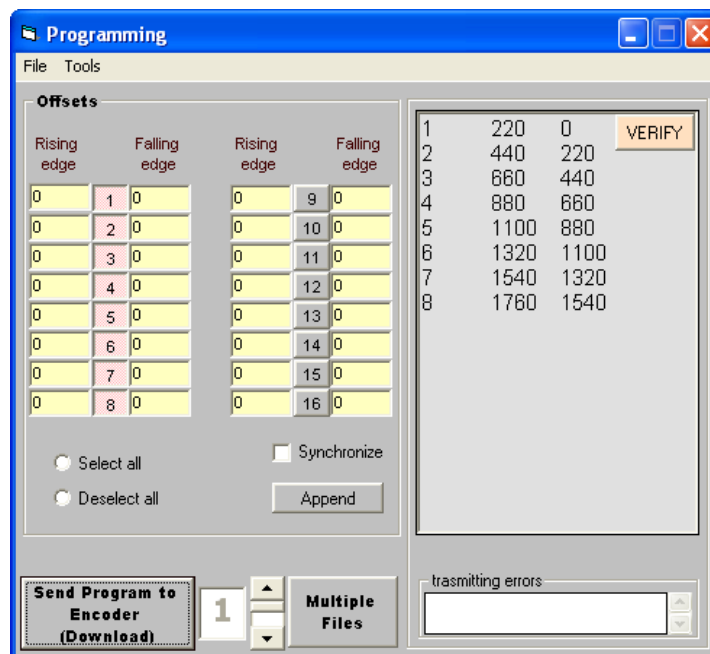

The buttons from 1 to 8 (one for each output) that appear in the **Offsets** pane are used to enable and disable the offset values; while buttons from 9 to 16 are not used. The offset values for the rising edge and the falling edge are to be set on the left side and on the right side of each button respectively. The enabled values will be calculated and applied to the program sent to the encoder.

If you want to see the complete list of data sent to the encoder, enlarge the programming window below; the **ok** message that appears at the end of each string means that the encoder has received data properly.

Verify

The **Verify** button allows to check the programming language syntax whenever you like.

Select all

Deselect all

It allows the operator to select or deselect all the eight buttons at the same time.

Synchronize

This function allows the operator to update the **Offsets** page using the new program data.

Append

It adds at the end of the program the offset values that appear in the **Offsets** page.



NOTE

It is important to know that the offset values used by the encoder are only those which have been set and activated in the **Offsets** page.

The offset values set in the program are considered only if the **Synchronize** check-box is selected and the values have not been changed any more in the field.

Send Program to Encoder (Download)

It allows the operator to download to the encoder the displayed program complete with the enabled offsets. The file will be downloaded in the program whose number is displayed on the right side of the button.

Multiple Files

This button is designed to download to the encoder the 16 files altogether simultaneously. In the box on the right of each line you can write the path where the file is located; otherwise you can click the number in each line and open the personal computer main window to find the desired file.

By clicking the **Send Program to Encoder (Download)** button, every listed file is sent to the encoder and saved in the program having the number of the line.

Note that a complete file list can be saved in and then loaded from the personal computer hard disk, see the next section.

6.4.1 File menu

Load Progr.

Save Progr.

It allows to upload a single program from the personal computer hard disk; it allows to save a single program to the personal computer hard disk (*.rcm format).

Load List

Save List

It allows to load a list of programs from the personal computer hard disk; it allows to save a list of programs to the personal computer hard disk (*.lis format).

Import (from ENCODER)

It allows the operator to upload the programs which are saved in the memory of the encoder. If the **Multiple Files** button below in the page is deselected, only the program whose number is indicated in the spin box on the left of the button is uploaded. Otherwise, if the **Multiple Files** button is selected, all the programs are saved in a .lis file (list file); then they are uploaded.

6.4.2 Settings menu

The **Settings** menu allows to enter the **Origin value** page.

In this page you can set, for each program, a preset value.

The Preset function is meant to assign a desired value to a specific physical position of the encoder shaft. The chosen physical position will get the value set in this page and all the previous and the following positions will get a value according to it. This function is useful, for example, when the zero position of the encoder and the zero position of the axis need to match. The preset value will be set for the position of the encoder in the moment when the preset value is activated. To activate the preset you must send a command through the Preset input, see the "4 - Electrical connection" section on page 16.

The preset value can be set, for each program, in the field of the **PRESET** column.

The **CLONE** button on the top of the **PRESET** column allows the operator to duplicate the preset value set for the program number 1 in all the other fifteen programs.

When you press the **READ** button, the program reads the preset values which

are set in each program saved in the encoder and then shows them in the **PRESET** column.

When you press the **SEND** button, the tool downloads the preset values set in the **PRESET** column to each program which is saved in the encoder.

The **ORIGIN** function is not implemented at the moment.

6.5 Work files (Working programs)

Programs to be sent to Rotacam can be edited using any text editor. Pay attention not to include formatting commands and characters.

The structure of a program is very simple. Every string must contain the complete command of the output: i.e. **number of the output** (from 1 to 8), **rising edge** and **falling edge**. The edge values are expressed in tenths of a degree.

Each output can be set with multiple command lines.



EXAMPLE

Setting the output number 7:

rising edge 198.5°; falling edge 300.0°,
rising edge 350.0°; falling edge 355.0°:

```
7    1985    3000
7    3500    3550
```

Values have to be separated using whatever non-numeric character but apex (') and ampersand (&). Space and Tab characters are always accepted by the editor. It is possible to add comments, they must be preceded by an apex (') delimiter; they are highlighted in blue.

' This is an example of comment

After programming the outputs, it is possible to program the offsets. The edge values must be separated from the offset values by using an ampersand (&).



EXAMPLE

```
8 0 2200 ' last programmed output
```

```
&          ' following strings are offset
           ' commands
```

```
3 120 -550 ' output n. 3 will be
```

- ' activated 12 degrees after rising
- ' edge and deactivated
- ' 55 degrees before falling edge

The offset value can be negative therefore meaning an advance. It must be comprised between -1800 and +1800 (higher values do not make any sense).



WARNING

Always insert a return carriage character after the last character in the last line (string).

6.5.1 Work files (Working programs) diagnostic

When you enter wrong commands or values, the internal diagnostic feature notifies the error and highlights it in different colour and bold in the **Programming** page. An important check is carried out on possible "overlapping" in quotes or after setting an offset.

Diagnostic feature does not warn of two particular "overlapping" cases having a specific aim:

- xx 0 0 ' used to set xx output always OFF**
- xx 1 1 ' used to set xx output always ON**

To delete an encoder program, download an empty program having the same number of the program you want to delete.

6.5.2 File extension

The file extension is not binding, the default extension for a single program is ".rcm"; while the default extension for a list of programs is ".lis".

Program list files can be edited using a text editor too. The syntax is: number of the program followed by SPACE or TAB characters and the complete path of the program file in round brackets.

- 1 (C:\programs\Rotacam\demo3.rcm)
- 7 (C:\Lika\Rotacam\demo6.rcm)

In the example, demo3.rcm will be downloaded to program 1 while demo6.rcm will be downloaded to program 7.

6.5.3 Errors

If a VB error message appears while installing the software, press **Continue** to go on.

Some applications, as a fax or a printer, keep the COM port open. If an error message informs you that the COM port is in use or not available, choose another COM port or temporarily close the application that causes the problem.

This page intentionally left blank

This page intentionally left blank

Document release	Release date	Description	HW	SW	Interface file version
1.0	11.10.2013	First issue	-	-	5.0
1.1	18.10.2017	General review	-	-	5.0



This device is to be supplied by a Class 2 Circuit or Low-Voltage Limited Energy or Energy Source not exceeding 30 Vdc. Refer to the order code for supply voltage rate.

Ce dispositif doit être alimenté par un circuit de Classe 2 ou à très basse tension ou bien en appliquant une tension maxi de 30Vcc. Voir le code de commande pour la tension d'alimentation.



Dispose separately

lika

Lika Electronic

Via S. Lorenzo, 25 • 36010 Carrè (VI) • Italy

Tel. +39 0445 806600

Fax +39 0445 806699



info@lika.biz • www.lika.biz